

---

# USER'S MANUAL (PART 2)

## ROOF MOUNT AIR CONDITIONER FOR ELECTRICAL ENCLOSURE INDOOR APPLICATION

# IP-ACIRM100.003



Document: UMA-CDZ- IP-ACIRM100.003-00		Date	Name
Description Original user's manual for air conditioner IP-ACIRM100.003 series Language: English	ISSUE	16/12/2022	.
	REV. 01		
	REV. 02		
	REV. 03		



## WARNING

- Safety of AIR CONDITIONER is warranted only by proper use of these instruction which must be kept.
- Installation must be done by qualified personnel only after enclosure power supply disconnecting.
- Before any operation, switch off the power supply.
- The appliance is classified as not accessible to the general public
- The air conditioner is not to be used by persons (including children) with reduced physical, sensory or mental capabilities, or lack of experience and knowledge, unless they have been given supervision or instruction.
- Children being supervised not to play with the air conditioner.
- The air conditioner must be installed in accordance with national wiring regulations (IEC 60335-2-40:2018)
- Upstream of the electrical connection, an efficient disconnection system must be provided in compliance with the AS / NSZ 3000 standard
- Internal and external components of electrical enclosure don't have to affect the proper installation of air conditioner.
- Inside of electrical enclosure there must not be components that could affect the proper ventilation.
- Provide a proper fixing of the electrical enclosure to the floor to prevent accidental tipping due to the supplementary weight of installed AIR CONDITIONER.
- Installation position of AIR CONDITIONER must be selected to ensure good ventilation. Take care that any internal/external components of enclosure don't obstruct air passage. (see section 2.2 GENERAL CHECKS BEFORE INSTALLATION)
- The heat loss of the components installed inside of the electrical enclosure must be lower than useful cooling power of the AIR CONDITIONER.
- AIR CONDITIONER IP-ACIW series must be handled in upright position and protected against accidental tipping over.
- Do not modify the AIR CONDITIONER structure if it is not specified in these instruction or associated instructions.
- During transportation of enclosures with installed air conditioner a proper bracket must be used to support the cooling unit weight.
- Install only original spare parts and accessories.
- Protection against access to live parts must be warranty by installer.
- The supply connector of the AIR CONDITIONER must only be connected and disconnected when electrical enclosure is electrically disconnected.
- Follow all technical data shown in this manual

# TABLE OF CONTENTS

WARNING .....	2
1 - TECHNICAL DATA.....	3
2 - INSTALLATION .....	4
2.1 PRODUCT HANDLING.....	4
2.2 GENERAL CHECKS BEFORE INSTALLATION .....	4
2.3 FITTING .....	5
3 - ELECTRICAL CONNECTION.....	7
3.1 WIRING DIAGRAM.....	7
4 - STARTING AND ADJUSTMENT .....	10
5 - STANDARD MODBUS.....	18
6 - SPARE PARTS LIST.....	20
WARRANTY.....	21
UE DECLARATION OF CONFORMITY.....	22
SAA CERTIFICATE.....	23

## 1 - TECHNICAL DATA

CONTROL TYPE			ARTICLE CODE
Digital thermostat with alarm, door interlock and RS485 serial interface			<b>IP-ACIRM100.003</b>
FEATURES		Unit	
Power supply		V   ph   Hz	230   1   50/60
Cooling capacity EN14511	A35-A35	W	1000/1060
	A35-A50	W	760/790
Absorbed electric power EN14511	A35-A35	W	780/810
	A35-A50	W	890/930
Rated current		A	5.1 / 6.2
Motor circuit breaker / Delayed pre fuse (advised)		A	10
Electrical connection		-	connector
Air flow rate (free blow)	enclosure	m3/h	600 / 625
Operating temperature	ambient	°C (°F)	+20  +55 (+68/+ 131)
	enclosure	°C (°F)	+20  +45 (+68/+ 113)
Refrigerant		-   g	R134a   500
Protection degree EN60529/1	ambient	-	IP34
	enclosure	-	IP54 (when installed on enclosure with the same protection degree)
Design	casing	-	Galvanised sheet steel
	cover	-	Galvanised sheet steel powder coated RAL7035
Weight		kg	36
Conformity / Certifications		-	CE, SAA 203165

# 2 - INSTALLATION

## 2.1 PRODUCT HANDLING



**AIR CONDITIONER IP- ACIRM series must be handled in upright position and protected against accidental tipping over.**

The air conditioner handling, when unpacked, can be done thanks to lifting eye bolt. Air conditioners IP-ACIRM series are fitted with lifting eye bolts.



**Check the proper fixing of eye bolts before lift the air conditioner.**

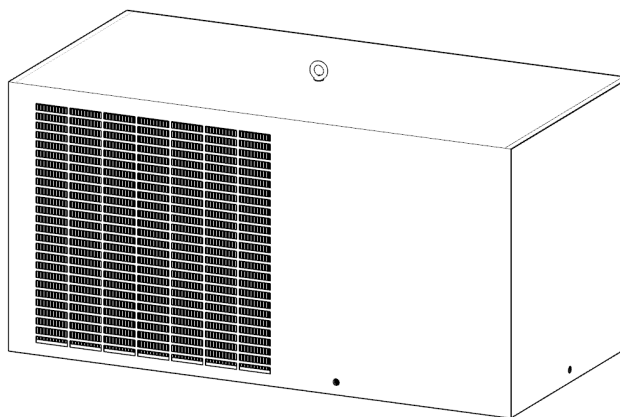

## 2.2 GENERAL CHECKS BEFORE INSTALLATION



**Before the installation make sure that the cabinet is disconnected from the electrical supply.**

GENERAL CHECKS
- electrical enclosure must be disconnected from power supply
- electrical data shown on rating label pasted on air conditioner side must be guaranteed
- Electrical enclosure must be sized according to air conditioner dimensions and weight.
- Electrical enclosure must have at least IP54 protection degree
- Internal and external components of electrical enclosure don't have to affect the proper installation of air conditioner
- The installation site must be free from excessive dirt, aggressive ambient conditions and moisture.
- The installation site must be free from hot air flows
- The internal side of electrical enclosure must be free from dirt and moisture
- The environment temperature must be within the range specified on label pasted on air conditioner side
- Inside of electrical enclosure there must not be components that could affect the proper ventilation
- the enclosure positioning with installed air conditioner must be carefully selected to ensure good ventilation (clearance between the air conditioner and the near walls must be at least 500 mm in each side).
- Proper disposing of condensate discharge

## 2.3 FITTING

1) Make the fixing hole on the enclosure as is shown in the drilling template

**VIEW FROM EXTERNAL OF ELECTRICAL ENCLOSURE**

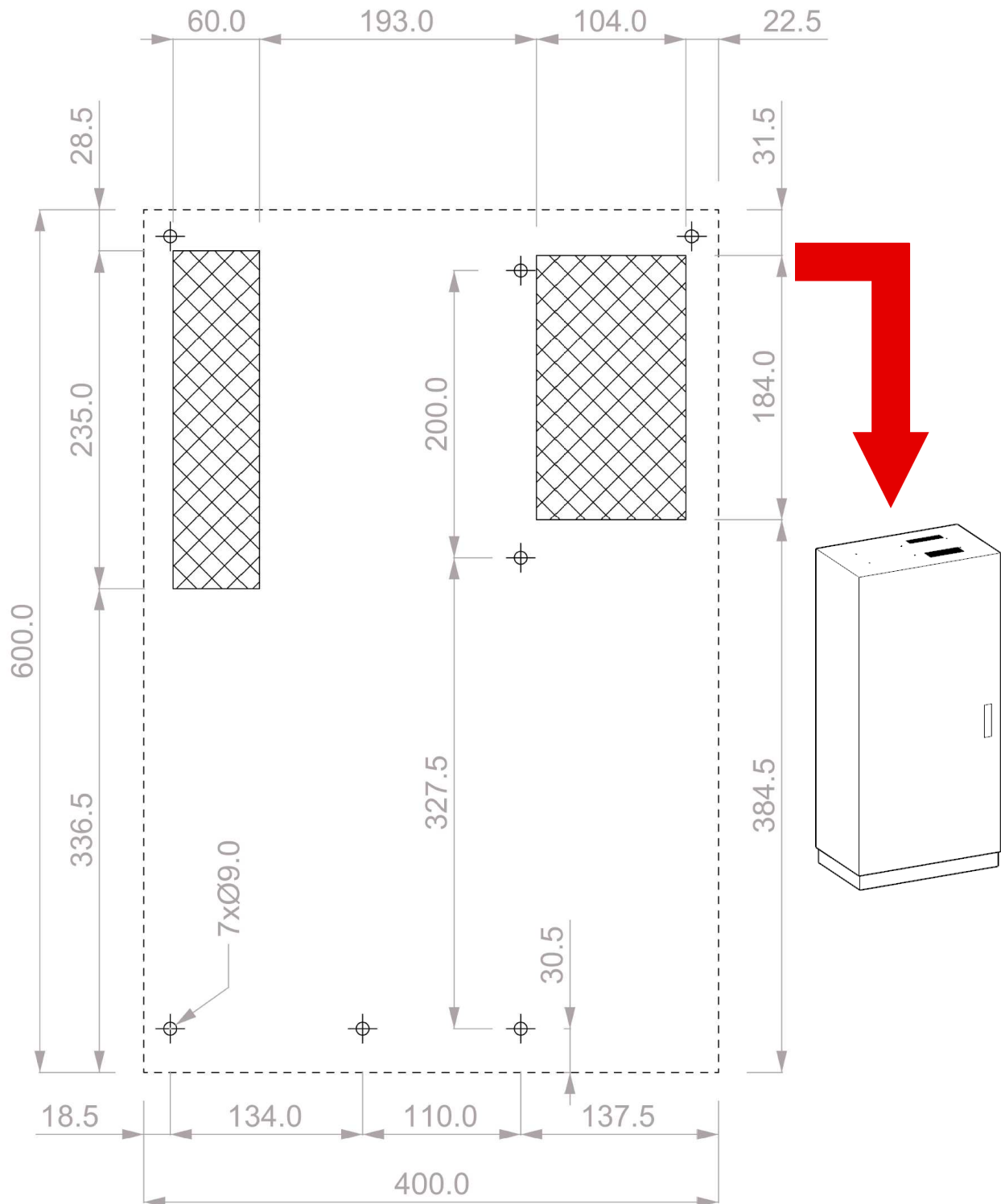

**Deburr all sharp edges to avoid accidental injuries**

- 2) Apply the gasket (included in fixing kit) on the bottom panel of the air conditioner.
- 3) Lift the air conditioner by lifting eyebolt and place on the enclosure roof

- 4) Mount the air conditioner on the electrical cabinet according to the drilling template with adequate M6 screws and washers against unscrewing (not included in mounting kit)
- 5) Connect adequate hoses to the condensate drain pipes as is shown by picture below. (IP-ACIRM100 series is fitted with two condensate drain pipes in order to ensure proper drainage in case of occlusion of a drain pipe)



**Air conditioner produces condensate because the moist air inside of the enclosure meets cold heat exchanger (evaporator) and then it becomes water; water production decreases during air conditioner working because enclosure air becomes dry.**

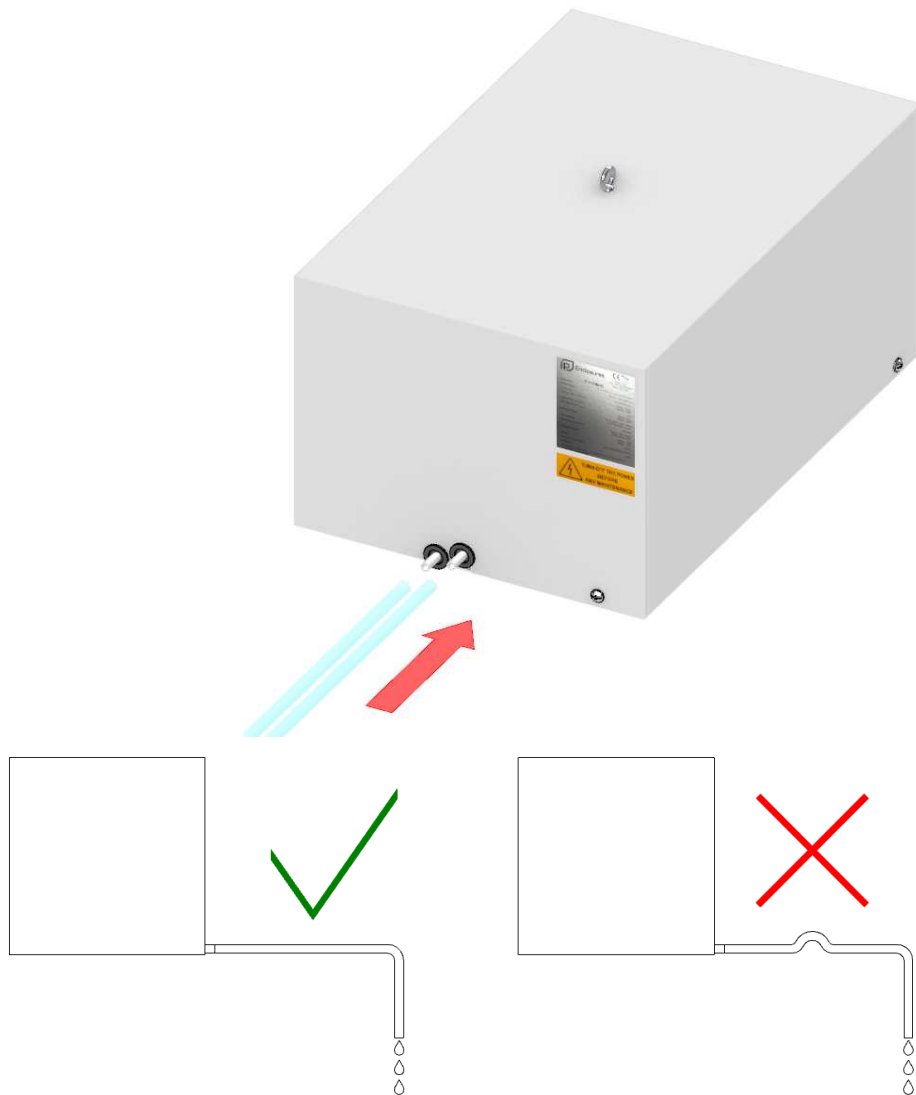

**The condensate must be properly evacuated to avoid accidental damage to the electrical enclosure**



**The enclosure must be IP54 protected, if enclosure is not airtight, condensate production could increase.**



**The enclosure IP54 degree is guaranteed only if the air conditioner is proper mounted.**

# 3 - ELECTRICAL CONNECTION

## 3.1 WIRING DIAGRAM

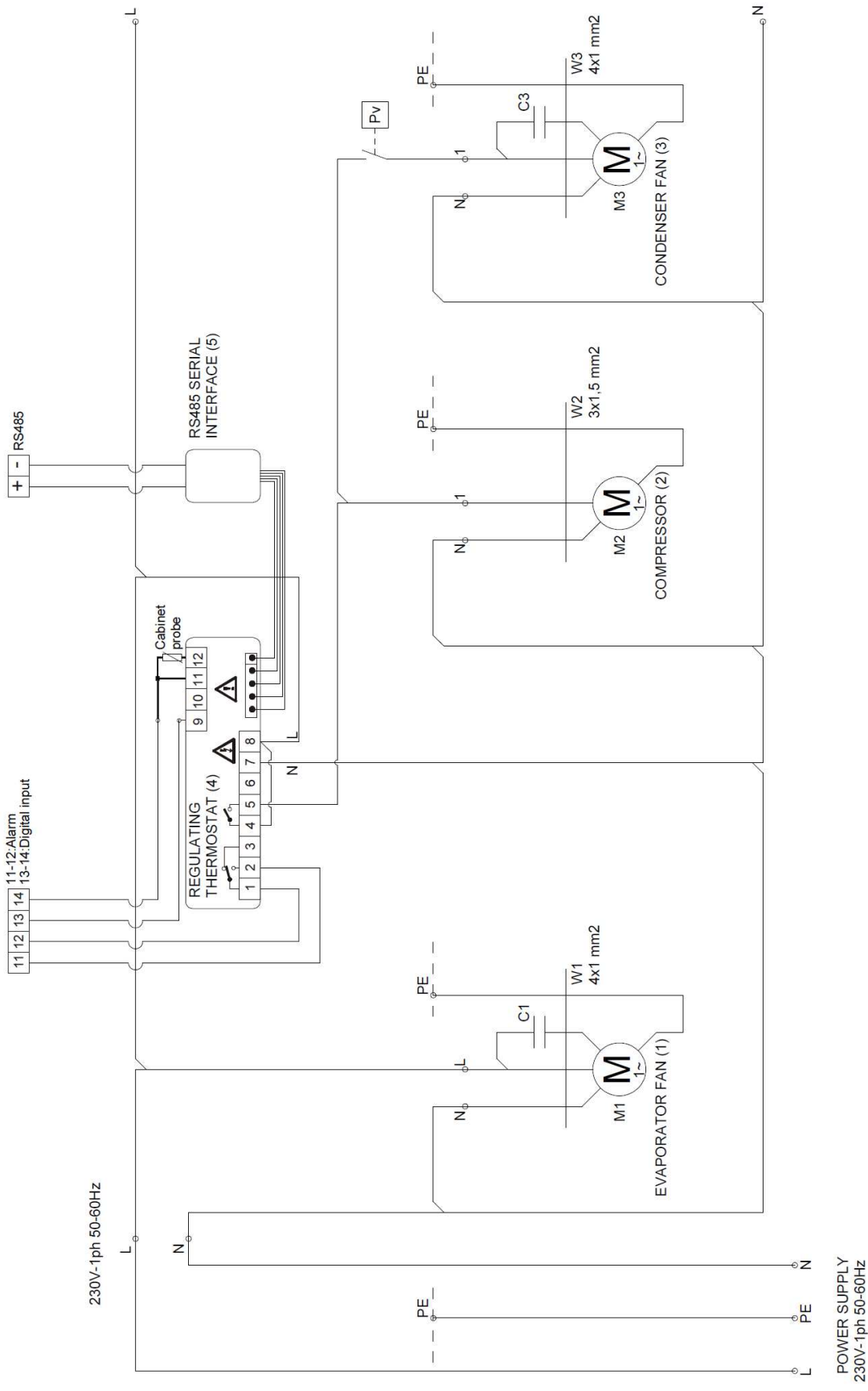

## 3.2 ELECTRICAL INSTALLATION



The electrical installation must be carried out by a qualified electrician who is responsible for compliance with the applicable standards and regulations.



Upstream of the electrical connection, a power line disconnecter must be provided in compliance with the AS / NSZ 3000 standard



Before the installation make sure that the cabinet is disconnected from the electrical supply.

Wire male plug (included) with an adequate cable as is shown by following picture



**Cable section must be at least 1,5mm<sup>2</sup>**

The male plug is fitted with spring terminals:

- 1) Push the spring with a screwdriver and then insert the wire.
- 2) Check the proper wire insertion.
- 3) Insert male connector inside of 3 poles female connector placed on the bottom of the air conditioner.

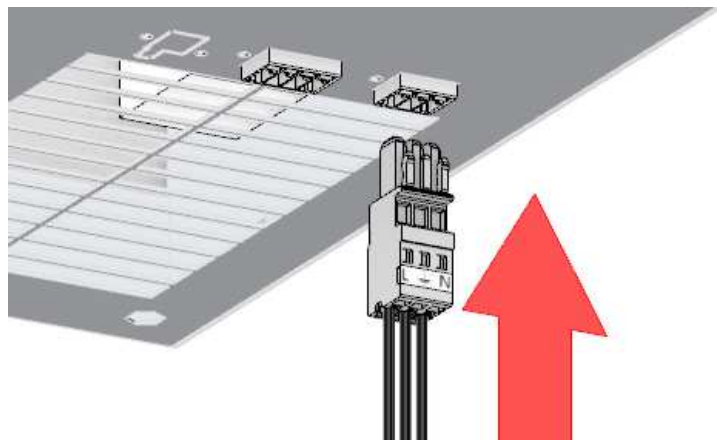
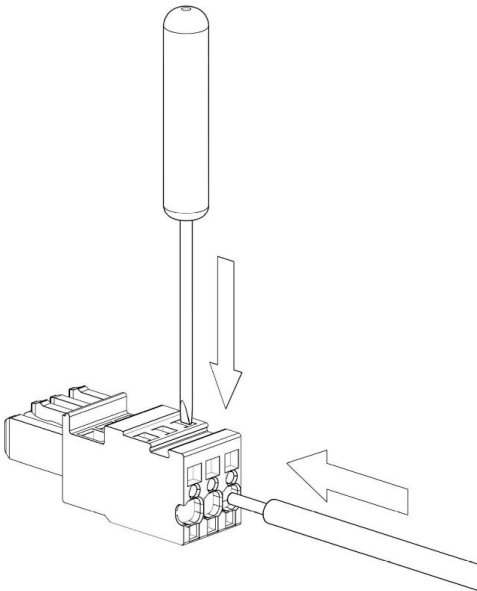

When the air conditioner is installed on electrical enclosure, female connector is accessible only from inside the enclosure.

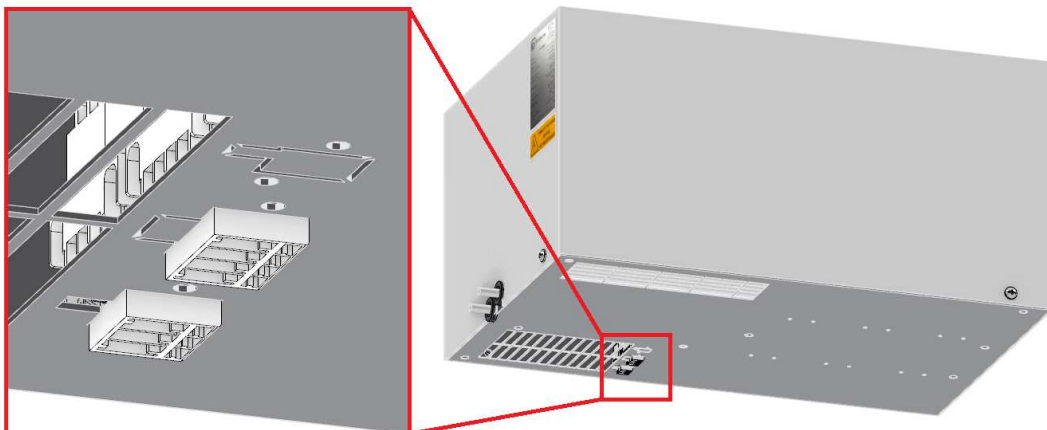

- 1) Insert signal connector (included in installation kit, refer to picture below) inside of 4 poles female connector placed on the bottom of the air conditioner.

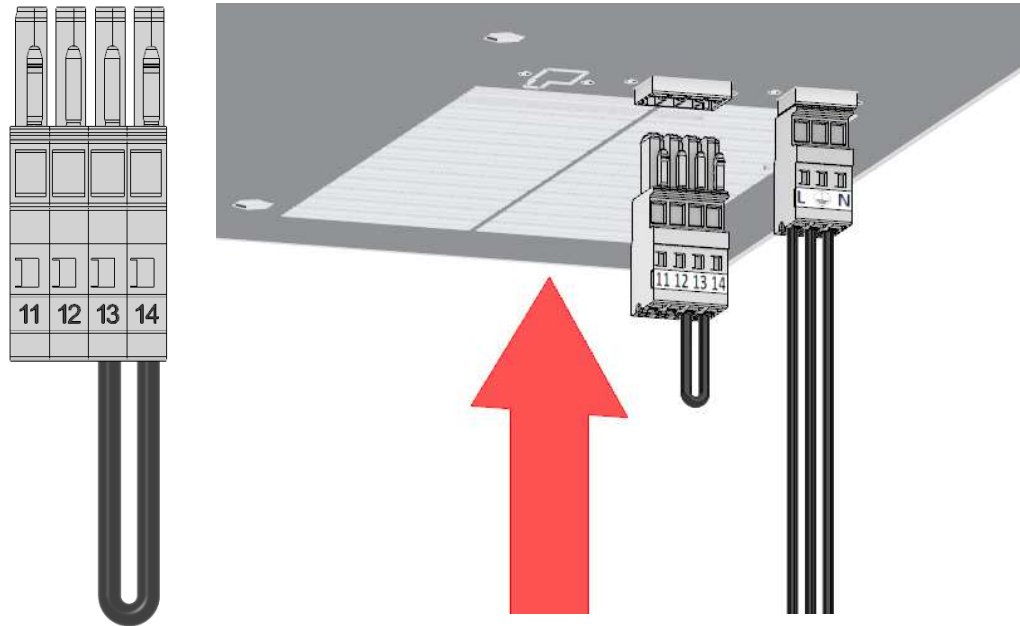

### 3.3 ALARM OUTPUT / DIGITAL INPUT

IP-ACIRM100 is fitted with an electronic controller which permits alarm output and digital input signals. Signals wiring is available on signals connector included in air conditioner packaging.

#### 3.3.1 Alarm output (poles 11-12)

Alarm output is activated according to alarm parameters (for example in case of enclosure temperature higher than ALU value, digital input not activated... See PARAMETERS at **4.2 DIGITAL THERMOSTAT INSTRUCTION** section)

Alarm output is a dry contact.

#### 3.3.2 Digital input (poles 13-14)



**WARNING: proper functions of air conditioner are allowed only if digital input is activated. (Closed contact between poles 13-14).**

**Poles 13-14 are factory wired with a bridge.  
Bridge can be removed to wire, for example, a door limit switch.**



**Electrical data shown on rating label, pasted on air conditioner side, must be followed**



**Install the delayed pre-fuse recommended to protect the line and enclosure components against short-circuit.**



**Upstream of the electrical connection, an efficient disconnection system must be provided and it must be clearly identified**



**Air conditioner is already fitted with a temperature controller, no additional temperature control must be connected upstream of the unit.**

## 4 - STARTING AND ADJUSTMENT

### 4.1 GENERAL DESCRIPTION

Air conditioners are especially designed for dissipation of heat loss inside electrical enclosures with IP54 protection degree.

Air circulation inside the enclosures allows to keep enclosure air volume isolated from external ambient air, it preserves the inside of the enclosure against dirt and humidity which are present in the external air.



**IP-ACIRM series must be installed only on the roof of electrical enclosure**

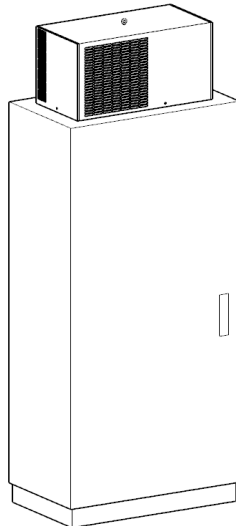

**After finishing assembly of the conditioner, wait approx. 30 min. before starting it (the oil must collect in the compressor to ensure lubrication and cooling).**

The air conditioner operates automatically, that is to say, after insertion, the evaporator fan operates continuously making the air inside the cabinet circulate. This way a uniform distribution of temperature inside the cabinet itself is attained. The built-in thermostat drives compressor and condenser fan according to set point value and other parameters (See PARAMETERS at **4.2 DIGITAL THERMOSTAT INSTRUCTION** section for references)

Compressor and condenser fan start after a delay set on thermostat (see parameter AC on parameters list for references) to permit a minimum interval between the compressor stop and the following restart.



**During proper operations, the compressor and condenser fan turn OFF when internal enclosure temperature decreases under set point value.**

## 4.2 DIGITAL THERMOSTAT INSTRUCTION



**WARNING:** the air conditioner is designed to operate at 35 ° C cabinet temperature. If the set point is changed the performance of the unit will vary.

- 1) Regulating thermostat is fixed air conditioner cover.
- 2) Thermostat could be set into a range from 20°C up to 50°C. Follow thermostat instructions for parameter changing.
- 3) **Factory parameters are especially set for the proper unit functionality, it is not suggested to change them.**

Setting parameters are divided in two menu: main menu and hidden menu.



**WARNING:** Some parameters collected in HIDDEN MENU are not needed for air conditioner operation, do not modify them.









<b>SET</b>	To display target set point; in programming mode it selects a parameter or confirm an operation.
	(DEF) To start a manual defrost
	To see the max. stored temperature; in programming mode it browses the parameter codes or increases the displayed value.
	To see the min stored temperature; in programming mode it browses the parameter codes or decreases the displayed value.
	To switch the instrument off, if onF = oFF.
	To switch the light, if oA1 = Lig

### 4.2.1 KEY COMBINATIONS:

	To lock & unlock the keyboard.
<b>SET</b> +	To enter in programming mode
<b>SET</b> +	To return to the room temperature display

#### 4.2.2 LED FUNCTION DESCRIPTION:

LED	MODE	FUNCTION
	ON	Compressor enabled
	Flashing	Anti-short cycle delay enabled
	ON	Defrost enabled
	ON	An alarm is occurring
	ON	Continuous cycle is running
	ON	Energy saving enabled
	ON	Light on
AUX	ON	Auxiliary relay on
°C/°F	ON	Measurement unit
°C/°F	Flashing	Programming phase

#### 4.2.3 MAX & MIN TEMPERATURE MEMORIZATION

##### How to see the min temperature

1. Press and release the ▼ key.
2. The “Lo” message will be displayed followed by the minimum temperature recorded.
3. By pressing the ▼ key again or by waiting 5s the normal display will be restored.

##### How to see the max temperature

1. Press and release the ▲ key.
2. The “Hi” message will be displayed followed by the maximum temperature recorded.
3. By pressing the ▼ key again or by waiting 5s the normal display will be restored.

##### How to reset the max and min temperature recorded

1. Hold press the **SET** key for more than 3s, while the max. or min temperature is displayed. (rSt message will be displayed)
2. To confirm the operation the “rSt” message starts blinking and the normal temperature will be displayed.

#### 4.2.4 HOW TO SEE THE SET POINT

1. Push and immediately release the **SET** key: the display will show the Set point value;
2. Push and immediately release the **SET** key or wait for 5 seconds to display the probe value again.

#### 4.2.5 HOW TO CHANGE THE SETPOINT

1. Push the **SET** key for more than 2 seconds to change the Set point value;
2. The value of the set point will be displayed and the “°C” or “°F” LED starts blinking;
3. To change the Set value push the ▲ or ▼ arrows within 10s.
4. To memorise the new set point value push the **SET** key again or wait 10s.

#### 4.2.6 HOW TO CHANGE A PARAMETER VALUE

To change the parameter’s value operate as follows:

1. Enter the Programming mode by pressing the **SET + ▼** keys for 3s (the “°C” or “°F” LED starts blinking).
2. Select the required parameter. Press the **SET** key to display its value
3. Use ▲ or ▼ to change its value.
4. Press **SET** to store the new value and move to the following parameter.

**To exit:** Press **SET + ▲** or wait 15s without pressing a key.

**NOTE:** the set value is stored even when the procedure is exited by waiting the time-out to expire.

#### 4.2.7 HOW TO LOCK THE KEYBOARD

1. Keep pressed for more than 3 s the **▲ + ▼** keys.
2. The **POF** message will be displayed and the keyboard will be locked. At this point it will be possible only to see the set point or the MAX o Min temperature stored
3. If a key is pressed more than 3s the **POF** message will be displayed.

#### 4.2.8 HOW TO UNLOCK THE KEYBOARD

Keep pressed together for more than 3s the **▲ + ▼** keys, till the **Pon** message will be displayed.

#### 4.2.9 THE ON/OFF FUNCTION

With **onF = oFF**, pushing the **ON/OFF** key, the instrument is switched off. The **OFF** message is displayed. In this configuration, the regulation is disabled.

To switch the instrument on, push again the **ON/OFF** key.

**WARNING:** Loads connected to the normally closed contacts of the relays are always supplied and under voltage, even if the instrument is in standby mode.

#### 4.2.10 MAIN MENU PARAMETERS

**Hy Differential:** (0,1 ÷ 25,5°C / 1÷255 °F) Intervention differential for set point. Compressor Cut IN is Set Point + differential (Hy). Compressor Cut OUT is when the temperature reaches the set point.



#### **DO NOT CHANGE THE VALUE OF Hy PARAMETER**

**Ot Thermostat probe calibration:** (-12.0÷12.0°C; -120÷120°F) allows to adjust possible offset of the thermostat probe.

**AC Anti-short cycle delay:** (0÷50 min) minimum interval between the compressor stop and the following restart.

**CH Type of action:** CL = cooling; Ht = heating. **(do not change this parameter)**

**rES Resolution (for °C):** (in = 1°C; dE = 0.1 °C) allows decimal point display. dLy Display delay: (0 ÷20.0m; risul. 10s) when the temperature increases, the display is updated of 1 °C/1°F after this time.

**IdF Interval between defrost cycles:** (0÷120h) Determines the time interval between the beginning of two defrost cycles. **(the air conditioner is not equipped with defrost, do not change this parameter)**

**MdF (Maximum) length for defrost:** (0÷255min) (0=no defrost) When P2P = n, (not evaporator probe: timed defrost) it sets the defrost duration, when P2P = y (defrost end based on temperature) it sets the maximum length for defrost. **(the air conditioner is not equipped with defrost, do not change this parameter)**

**ALU MAXIMUM temperature alarm:** (SET÷110°C; SET÷230°F) when this temperature is reached the alarm is enabled, after the "ALd" delay time.

**ALL Minimum temperature alarm:** (-50.0 ÷ SET°C; -58÷230°F) when this temperature is reached the alarm is enabled, after the "Ald" delay time.

**I1P Digital input polarity:** oP: the digital input is activated by opening the contact; CL: the digital input is activated by closing the contact.

- i1F Digital input configuration:** EAL = external alarm: “EA” message is displayed; bAL = serious alarm “CA” message is displayed. PAL = pressure switch alarm, “CA” message is displayed; dor = door switch function; dEF = activation of a defrost cycle; AUS = to switch on the second relay if oA1 = AUS; Htr = kind of action inversion (cooling –heating); Fan = not set it; ES = Energy saving.
- Did** (0 ÷ 255 min) with i1F= EAL or i1F = bAL digital input alarm delay: delay between the detection of the external alarm condition and its signalling.  
With i1F= dor: door open signalling delay  
with i1F = PAL: time for pressure switch function: time interval to calculate the number of the pressure switch activation.
- PbC Type of probe:** it allows to set the kind of probe used by the instrument: PbC = PBC probe, ntc = NTC probe. **(the air conditioner is fitted with NTC probe, do not change this parameter)**
- dP3 Third probe display-** no available  
**dP4 Fourth probe display-** no available

#### 4.2.11 DIGITAL INPUT (ENABLED WITH P3P = N)

The free voltage digital input is programmable in different configurations by the “i1F” parameter.

##### Door switch input (i1f = dor)

It signals the door status and the corresponding relay output status through the **odc** parameter:

**no**= normal (any change);, **Fan**= fan OFF; **CPr**= Compressor OFF, **F\_C**= Compressor and fan OFF.

Since the door is opened, after the delay time set through parameter **did**, the door alarm is enabled, the display shows the message **dA** and the regulation restarts is **rtr = yES**. The alarm stops as soon as the external digital input is disabled again. With the door open, the high and low temperature alarms are disabled.

##### Digital inputs polarity

The digital input polarity depends on the **i1P** parameter.

**i1P=CL:** the input is activated by closing the contact.

**i1P=OP:** the input is activated by opening the contact

#### 4.2.12 GENERIC ALARM (i1F = EAL)

As soon as the alarm input is activated (for example enclosure temperature higher than ALU value) the unit will wait for **did** time delay before signalling the **EAL** alarm message. The outputs status doesn’t change. The alarm stops just after the alarm input is de-activated.

#### 4.2.13 SERIOUS ALARM MODE (i1F = bAL)

When the alarm input is activated (for example enclosure temperature higher than ALU value), the unit will wait for **did** delay before signalling the **CA** alarm message. The relay outputs are switched OFF. The alarm will stop as soon as the alarm input is de-activated.

#### 4.2.14 ALARM SIGNALS

Mess age	Cause	Outputs
"P1"	Room probe failure	Compressor output acc. to par. "Con" and "COF"
"P3"	Third probe failure	Outputs unchanged
"P4"	Fourth probe failure	Outputs unchanged
"HA"	Maximum temperature alarm	Outputs unchanged.
"LA"	Minimum temperature alarm	Outputs unchanged.
"HA2"	Condenser high temperature	It depends on the "Ac2" parameter
"LA2"	Condenser low temperature	It depends on the "bLL" parameter
"dA"	Door open	Compressor according to rrd
"EA"	External alarm	Output unchanged.
"CA"	Serious external alarm (i1F=bAL)	All outputs OFF.
"CA"	Pressure switch alarm (i1F=PAL)	All outputs OFF
"rtc"	Real time clock alarm	Alarm output ON; Other outputs unchanged; Defrosts according to par. "IdF" Set real time clock has to be set
rtF	Real time clock board failure	Alarm output ON; Other outputs unchanged; Defrosts according to par. "IdF" Contact the service

#### 4.2.15 DEFAULT SETTING VALUES



**THE LIST OF PARAMETERS IS DISPLAYED ONLY TO ALLOW THE PARAMETERS SET AT THE FACTORY TO BE RESTORED IN CASE OF ACCIDENTAL CHANGES. IT IS STRONGLY RECOMMENDED NOT TO CHANGE THE FACTORY SETS, THE FUNCTIONING OF THE UNIT MAY BE AFFECTED**

Parameter	Menu	Description	Range	Factory set
Set	MAIN MENU	Set point	LS÷US	31
Hy	MAIN MENU	Differential	0,1÷25.5°C/ 1÷ 255°F	4
LS	HIDDEN MENU	Minimum set point	-50°C÷SET/-58°F÷SET	20
US	HIDDEN MENU	Maximum set point	SET÷110°C/ SET ÷ 230°F	50
ot	MAIN MENU	Thermostat probe calibration	-12÷12°C /-120÷120°F	0
P3P	HIDDEN MENU	Third probe presence	n=not present; Y=pres.	n
O3	HIDDEN MENU	Third probe calibration	-12÷12°C /-120÷120°F	0
P4P	HIDDEN MENU	Fourth probe presence	n=not present; Y=pres.	n
O4	HIDDEN MENU	Fourth probe calibration	-12÷12°C /-120÷120°F	0
OdS	HIDDEN MENU	Outputs delay at start up	0÷255 min	0
AC	MAIN MENU	Anti-short cycle delay	0 , 50 min	1
CCt	HIDDEN MENU	Continuos cycle duration	0.0÷24.0h	0
CCS	HIDDEN MENU	Set point for continuous cycle	(-55.0÷150,0°C) (-67÷302°F)	3
CO <sub>n</sub>	HIDDEN MENU	Compressor ON time with faulty probe	0÷255 min	15
CO <sub>F</sub>	HIDDEN MENU	Compressor OFF time with faulty probe	0÷255 min	30

CH	MAIN MENU	Kind of action	CL=cooling; Ht= heating	CL
CF	HIDDEN MENU	Temperature measurement unit	°C ÷ °F	°C
rES	MAIN MENU	Resolution	in=integer; dE= dec.point	dE
dLy	HIDDEN MENU	Display temperature delay	0 ÷ 20.0 min (10 sec.)	0
IdF	MAIN MENU	Interval between defrost cycles	1 ÷ 120 h	8
MdF	MAIN MENU	(Maximum) length for defrost	0 ÷ 255 min	0
dFd	HIDDEN MENU	Displaying during defrost	rt, it, SEt, DEF	it
dAd	HIDDEN MENU	MAX display delay after defrost	0 ÷ 255 min	30
AIC	HIDDEN MENU	Temperat. alarms configuration	rE= related to set; Ab = absolute	Ab
ALU	MAIN MENU	MAXIMUM temperature alarm	Set÷110.0°C; Set÷230°F	50
ALL	MAIN MENU	Minimum temperature alarm	-50.0°C÷Set/ -58°F÷Set	-50
AFH	HIDDEN MENU	Differential for temperature alarm recovery	(0,1°C÷25,5°C) (1°F÷45°F)	5
ALd	HIDDEN MENU	Temperature alarm delay	0 ÷ 255 min	0
dAo	HIDDEN MENU	Delay of temperature alarm at start up	0 ÷ 23h e 50'	0
AP2	HIDDEN MENU	Probe for temperat. alarm of condenser	nP; P1; P2; P3; P4	P4
AL2	HIDDEN MENU	Condenser for low temperat. Alarm	(-55 ÷ 150°C) (-67÷ 302°F)	-40
AU2	HIDDEN MENU	Condenser for high temperat. Alarm	(-55 ÷ 150°C) (-67÷ 302°F)	110
AH2	HIDDEN MENU	Differ. for condenser temp. alar. recovery	[0,1°C ÷ 25,5°C] [1°F ÷ 45°F]	5
Ad2	HIDDEN MENU	Condenser temperature alarm delay	0 ÷ 254 (min.) , 255=nU	15
dA2	HIDDEN MENU	Delay of cond. temper. alarm at start up	0.0 ÷ 23h 50'	1,3
bLL	HIDDEN MENU	Compr. off for condenser low temperature alarm	n(0) - Y(1)	n
AC2	HIDDEN MENU	Compr. off for condenser high temperature alarm	n(0) - Y(1)	n
tbA	HIDDEN MENU	Alarm relay disabling	n=no; y=yes	n
oA1	HIDDEN MENU	2nd relay configuration	ALr = alarm; dEF = do not select it; Lig =Light; AUS =AUX; onF=always on; Fan= do not select it; db = do not select it; dF2 = do not select it	Alr
AOP	HIDDEN MENU	Alarm relay polarity (oA1=ALr)	oP; cL	cL
i1P	MAIN MENU	Digital input polarity	oP=opening;CL=closing	oP
i1F	MAIN MENU	Digital input configuration	EAL, bAL, PAL, dor; dEF; Htr,AUS	dor
did	MAIN MENU	Digital input alarm delay	0 ÷ 255 min	0
nPS	HIDDEN MENU	Number of activation of pressure switch	0 ÷ 15	15
odC	HIDDEN MENU	Compress status when open door	no; Fan; CPr; F_C	CPr
rrd	HIDDEN MENU	Regulation restart with door open alarm	n – Y	n
HES	HIDDEN MENU	Differential for Energy Saving	(-30°C÷30°C) (-54°F÷54°F)	0
Adr	HIDDEN MENU	Serial address	0÷247	1

PbC	MAIN MENU	Kind of probe	Ptc; ntc	ntc
OnF	HIDDEN MENU	on/off key enabling	nu, oFF; ES	noP
dP3	MAIN MENU	Third probe display		noP
dP4	MAIN MENU	Fourth probe display		noP
rSE	HIDDEN MENU	Real set point value	actual set	31
rEL	HIDDEN MENU	Software release		1
Ptb	HIDDEN MENU	Map code		4

The hidden menu includes all the parameters of the instrument.



**WARNING: Some parameters collected in HIDDEN MENU are not needed for air conditioner operation, do not modify them.**

#### 4.2.16 HOW TO ENTER IN THE HIDDEN MENU

- 1) Enter the Programming mode by pressing the Set + ▼ keys for 3s (the “°C” or “°F” LED starts blinking).
- 2) Released the keys, then push again the Set+▼ keys for more than 7s. The Pr2 label will be displayed immediately followed from the HY parameter.
- 3) Select the required parameter.
- 4) Press the “SET” key to display its value
- 5) Use ▲ or ▼ to change its value.
- 6) Press “SET” to store the new value and move to the following parameter.  
To exit: Press SET + ▲ or wait 15s without pressing a key.

NOTE: the set value is stored even when the procedure is exited by waiting the time-out to expire.

## 5 - STANDARD MODBUS

### 5.1 COMMUNICATION SETTING

BAUDRATE	9600
DATA LENGHT	8 bits
PARITY	NONE
STOP	1 bit
MINIMUM TIMEOUT	60ms
MODBUS DEFAULT UNIT ADDRESS	1

### 5.2 MODBUS TABLE

DESCRIPTION	PARAMETER	ADDRESS	R/W
TEMPERATURE DETECTED BY THE PROBE		0108	R
SET POINT	SEt	035F	R/W
DIFFERENTIAL	Hy	0300	R/W
MINIMUM SET POINT	LS	0301	R/W
MAXIMUM SET POINT	US	0302	R/W
THERMOSTAT PROBE CALIBRATION	ot	0303	R/W
COOLING		021E	R
OPEN DOOR		0212	R
ALARM		0219	R
ERROR PROBE		0208	R
OUTPUTS DELAY AT START UP	odS	030A	R/W
ANTI-SHORT CYCLE DELAY	AC	030B	R/W
COMPRESSOR ON TIME WITH FAULTY PROBE	Con	0310	R/W
COMPRESSOR OFF TIME WITH FAULTY PROBE	CoF	0311	R/W
TEMPERATURE ALARMS CONFIGURATION	ALC	0339	R/W
MAXIMUM TEMPERATURE ALARM	ALU	033A	R/W
MINIMUM TEMPERATURE ALARM	ALL	033B	R/W
DIFFERENTIAL FOR TEMPERATURE ALARM RECOVERY	AFH	033C	R/W
TEMPERATURE ALARM DELAY	ALd	033D	R/W
DELAY OF TEMPERATURE ALARM AT START UP	dAo	033E	R/W
SERIAL ADDRESS	Adr	0353	R/W

### 5.3 RS485 CONNECTING

- 1) Unsheathe 30 mm of the end of the RS485 cable.
- 2) Shorten unused insulated conductors flush with the cable sheath.
- 3) Strip off the conductor insulation by 8 mm.
- 4) Wire the RS485 conductor to the supplied two-pole plug. Observe assignments printed on the plug

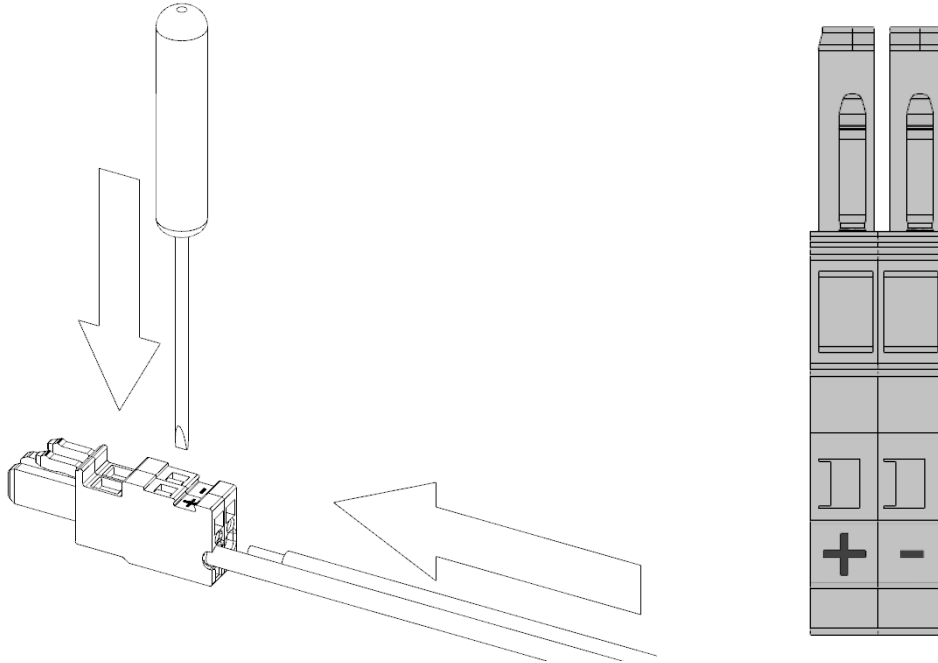

- 5) Plug the two-pole plug into the RS485 port on the air conditioner.

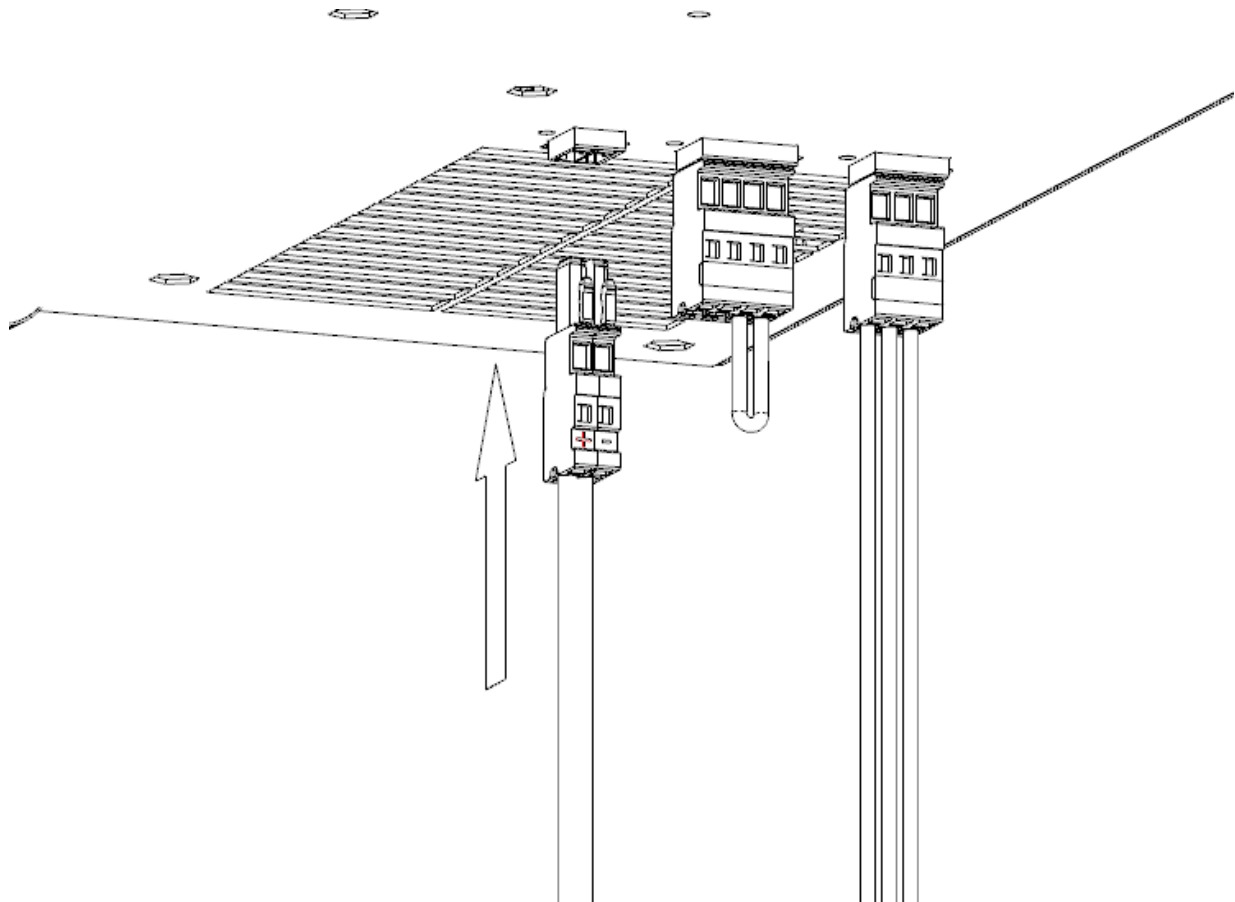

## 6 - SPARE PARTS LIST

REFERRED TO WIRING DIAGRAM	DESCRIPTION	CODE
1	Evaporator fan	VCENT190D230V
2	Compressor	COMPRSC12G
3	Condenser fan	VCENT220D230U
C1	Evaporator fan capacitor	CON2UFS2M8F
C3	Condenser fan capacitor	CON2UFS2M8F
4	Regulating thermostat	TERMDIG1S1D2R
5	RS485 Serial interface	XJ485CX
6	Regulating thermostat	TERM.ALL.COND
	Supply connector (male plug)	SPINALIM3.1
	Signals connector (male plug)	SPIN-SEGN4
	RS485 connector (male plug)	SPIN-RS485

# WARRANTY

WE  
IP ENCLOSURES



**guarantees that the product is free from any quality defects.**

The product is guaranteed for a period of 12 months from the date of delivery, provided it operates under the following conditions:

1. value of power supply indicated in the data plate is completely respected;
2. requirements specified on user's manual are completely respected;
3. cabinet temperature is not higher or lower than its rated temperature;
4. ambient temperature is not higher or lower than its rated temperature;
5. the product is mounted on cabinets with a minimum IP54 protection level;
6. the product is mounted on cabinets that not requiring higher cooling power than expected;
7. the product is clearly identifiable by serial number.

The warranty does not apply if :

1. the cooling circuit has been modified about type and quantity of refrigerant or composition;
2. the unit operates in acid or corrosive ambient;
3. the unit has been modified without IP ENCLOSURES consent.

This warranty shall become null as soon as the product is altered or modified in its structure or in circuits.

The terms of this warranty (commencement and termination dates) are not modified by any repair or replacement of products.

For every part that results defective during the period of this warranty, IP ENCLOSURES shall repair or replace it. Any others charges arising from removal, handling and installation of the products shall not be refunded by IP ENCLOSURES.

Like is specified on user's manual, installation, handling, the correct earthing in accordance with all current standards are under the responsibility of costumer.

In the event of any damage caused by a defective product shall apply the EEC85.374 standard.

The malfunction must be communicated in writing to IP ENCLOSURES.

Warranty is void if the costumer is not in good standing with the payments

# UE DECLARATION OF CONFORMITY



WE  
IP ENCLOSURES



DECLARE THAT THE AIR CONDITIONER FOR ELECTRICAL CABINETS

## IP-ACIRM series

DO COMPLY WITH THE FOLLOWING DIRECTIVES

**2006/42/CE** MACHINERY DIRECTIVE (17 May 2006)

**2014/35/UE** LOW VOLTAGE DIRECTIVE (26 February 2014)

**2014/30/UE** EMC DIRECTIVE (26 February 2014)

**2011/65/UE** ROHS DIRECTIVE (8 June 2011)

STANDARDS APPLIED TO MEET THE PRINCIPAL ELEMENTS OF THE DIRECTIVE

**EN 60335-2-40:2003; A1; A2** (IEC 60335-2-40: 2002; A1; A2)

**EN 60335-1: 2010; A11; A13; A14; A1; A2** (IEC 60335-1; A1; A2)

OTHER STANDARDS APPLIED

**EN 55014-1: 2017**

**EN 55014-2: 2015**

**EN IEC 61000-3-2: 2019**

**EN 61000-3-3: 2013**

		Date	Name
<b>Description</b> Declaration of Conformity for air conditioner IP-ACIW	ISSUE	01/06/2020	
	REV. 1		
	REV. 2		
	REV. 3		

# SAA CERTIFICATE



## Certificate of Suitability

**\*Addendum\***

**Certificate No.:** SAA203165

**Date of Issue:** 28 March 2022

**Regulatory Definition:** Non-Declared  
**Product Description:** Air-conditioning unit for cabinet

Additional Models	Trade Name	Rating/Marking
IP-ACIRM050.002	IP Enclosures	230Vac 50/60Hz Max 300W R134a/250g, Max Pressure: 2400kPA Class I, IP34 (External side), IP54 (Internal side)
IP-ACIRM050.003	IP Enclosures	230Vac 50/60Hz Max 300W R134a/250g, Max Pressure: 2400kPA Class I, IP34 (External side), IP54 (Internal side)
IP-ACIRM100.002	IP Enclosures	230Vac 50/60Hz Max 890W R134a/500g, Max Pressure: 2400kPA Class I, IP34 (External side), IP54 (Internal side)
IP-ACIRM100.003	IP Enclosures	230Vac 50/60Hz Max 890W R134a/500g, Max Pressure: 2400kPA Class I, IP34 (External side), IP54 (Internal side)
IP-ACIRM150.002	IP Enclosures	230Vac 50/60Hz Max 1050W R134a/500g, Max Pressure: 2400kPA Class I, IP34 (External side), IP54 (Internal side)
IP-ACIRM150.003	IP Enclosures	230Vac 50/60Hz Max 1050W R134a/500g, Max Pressure: 2400kPA Class I, IP34 (External side), IP54 (Internal side)
IP-ACIRM200.002	IP Enclosures	230Vac 50/60Hz Max 1100W R134a/750g, Max Pressure: 2400kPA Class I, IP34 (External side), IP54 (Internal side)
IP-ACIRM200.003	IP Enclosures	230Vac 50/60Hz Max 1100W R134a/750g, Max Pressure: 2400kPA Class I, IP34 (External side), IP54 (Internal side)

For and on Behalf of  
SAA Approvals Pty Ltd

SAA certifies the product nominated in this certificate  
complies with standards listed above.

For SAA Contact Details and to verify this Certificate go to:  
[www.sasapprovals.com.au](http://www.sasapprovals.com.au)



Issued: 28-03-22 203165/7

