

S2 Electrical Enclosure

IP-L8010030

STEEL | DOUBLE DOOR | IP55

800H x 1000W x 300D

The S2 range of electrical enclosures are rated for protection up to IP55. This range is wall-mounted, powder-coated galvanised steel, double door construction suitable for heavy duty applications.

Protection: IP55 IK10 (NEMA 3)

Standards (& Conformities): IEC/EN 60529, IEC/EN 62208, IEC/EN 61439, RoHS



Material:

- Body: 1.5mm galvanised steel sheet
- Gland Plate: 1.5mm galvanised steel sheet
- Door: 1.5mm galvanised steel sheet
- Device Mounting Plate: 1.5mm galvanised steel sheet
- Seal: Polyurethane

Enclosure Body: The robust monoblock body is fabricated using 1.5mm galvanised steel sheet. Flat face sealing surfaces are provided to increase seal life. Pre-fitted blind nutserts are incorporated to accommodate mounts and accessory fasteners to eliminate drilling and retain IP rating. Integral device plate mounts and M6 earth studs are provided. Gland plates are incorporated into the bottom face. Cutting, pressing and full continuous seam welding using precision automated manufacturing equipment ensures accuracy and consistent high quality.

Enclosure Door: The robust surface mounted doors are fabricated using 1.5mm galvanised steel sheet and incorporate concealed removable hinges with captive pins. The doors are designed to eliminate the central mullion to improve accessibility into the enclosure. The doors are designed for a 110° opening. Each door contains integral cable management rails, an M6 earth stud and a high quality machine-applied foamed in place (FIP) Polyurethane seal. Internal cable management rails can be removed to provide additional space for equipment, duct and door mounted control components.

Enclosure Seal: A high quality machine-applied full perimeter UL listed Polyurethane seal foamed in place (FIP) provides excellent sealing over a long life. Temperature resistance -40°C to 80°C (160°C short term loading).

Enclosure Lock: 3 point locking system with key-lock swing handle.

Device Mounting Plate: The device mounting plate is 1.5mm galvanised steel sheet. It is pressed to provide strength and is pre-fitted into the enclosure as standard.

Gland Plate: Gland plates are incorporated into the bottom face of the enclosure for cable management. They are provided with gaskets and fasteners. The size and quantity vary according to enclosure size.

Surface Treatment: UL approved AkzoNobel epoxy polyester powder-coated with a textured finish. 80-120 micron average thickness. Colour RAL7035.

Mass: 45Kg.

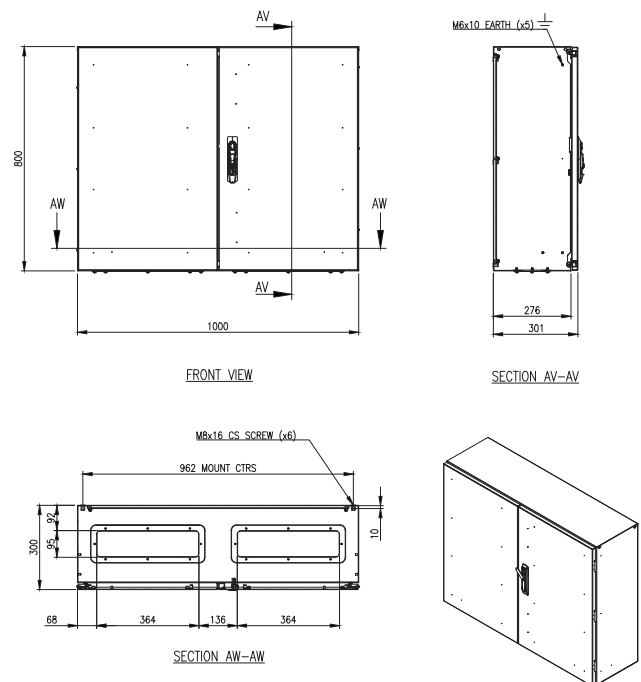

S2 Electrical Enclosure

IP-L8010030

STEEL | DOUBLE DOOR | IP55

800H x 1000W x 300D

ACCESSORIES:

Part Number	Description
IP-GPB3-3; IP-GPA3-3; IP-GPBA5-3	3mm Brass; 3mm Aluminium; 5mm Aluminium Gland Plates
IP-EK01	Standard Earthing Kit
IP-WMBKIT	Wall-Mounting Bracket Kit (with 4x Brackets and Fasteners)

CERTIFICATES:

IEC 60529 Degrees of protection provided by enclosures: Certificate AB-0386-T 1610.05.01/00
IEC/EN 62208 Empty Enclosures for low-voltage switchgear and controlgear assemblies: Certificate 0366932-TSE-01/01
IEC/EN61439-1, 61439-2 low voltage switchgear and controlgear assemblies: Certificate AB-0341-T, 23-314-R1-N1-1
CE Certificate of Compliance: Certificate SZT-24 MA 33485-1
UKCA Certificate of Compliance: Certificate SZT-25 MA 38734-1

IEC/EN 61439 Certified Test Ratings:

Rated Voltage: 400 V AC
Rated Insulation Voltage: 690 V
Rated Impulse Withstand Voltage: 6 kV
Rated Current: 630A
Rated Peak Withstand Voltage: 40kA
Rated Short-Time Withstand Current: 20kA (Busbar)
Rated Conditional Short Circuit Current: 20kA
Rated Frequency: 50Hz

Products are manufactured to Quality, Safety and Environmental Standards.

WARRANTY: 5 years.