

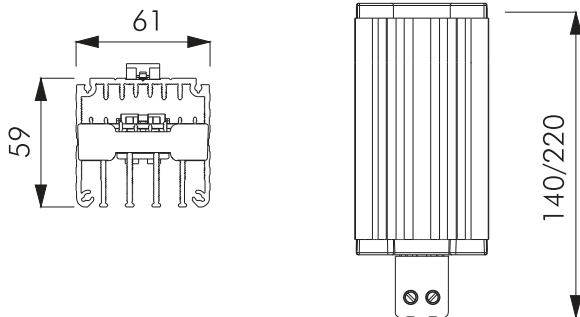

Compact | 25W to 150W

IP Enclosures provide a wide range of heating products for electrical enclosures. Anti-condensation heaters are required to prevent failures or corrosion caused by low temperatures or high humidity inside the enclosure. This occurs when ambient temperature is low and the equipment does not generate enough heat to maintain the minimum internal temperature. IP Enclosures heating products are manufactured to the highest quality in Italy.



FEATURES	UNIT	IP-H25	IP-H50	IP-H75	IP-H100	IP-H150
Heating Capacity*	W	25	50	75	100	150
Power supply	V	120-240V AC or DC				
24V Voltage Availability	V	IP-H50.24			IP-H100.24	
48V Voltage Availability	V				IP-H100.48	
Inrush current	A	2.5	3.5	4	5	9.5
Delayed fuse (advised)	A	4	4	6.3	8	10
Electrical connections		2 screw terminals for stranded or rigid wire 2.5 m ²				
Protection Class	-	Class II				
Protection degree EN60529	-	IP20				
Operating temperature	°C (°F)	-45/+70 (-49/+158)				
Storage temperature	°C (°F)	-45/+80 (-49/+176)				
Dimensions HxWxD	mm	128x59x61	100x40x40		140x59x61	220x59x61
Weight (with packaging)	kg		0.24 (0.28)		0.34 (0.38)	0.57 (0.62)
Conformity/Certifications	-	UKCA, CE - UL 				
VERSIONS						
with Integrated fixed thermostat NC 5°C		IP-H25.001	IP-H50.001	IP-H75.001	IP-H100.001	IP-H150 .001