

FCA Field Cabinet

IP-A453522-GRN

ALUMINIUM | POLE MOUNT | VENTILATED | IP55 IK10

450H x 350W x 225D

Pole-Mounted Aluminium Field Cabinets are designed to house sensitive data network and electrical equipment for a variety of heavy duty outdoor applications including general industrial, infrastructure, road/traffic management and intelligent transport systems.

Protection: IP55 IK10

Standards (& Conformities): IEC/EN 60529, IEC/EN 62208, EIA-310-D, RoHS



Material:

- Body: 2.5mm Marine Grade Aluminium 5754-H111
- Door: 2.5mm Marine Grade Aluminium 5754-H111
- Device Mounting Plate: 1.5mm galvanised steel sheet
- Seal: Polyurethane

Body: The robust monoblock body is fabricated using 2.5mm marine grade aluminium and is pressed to provide flush recessed mounting of the door to prevent vandalism and unauthorised access. Precision automated manufacturing equipment ensures accuracy and consistent high quality. Flat face sealing surfaces increase seal life. Integral device plate mounts and M6 earth studs are included. Fan/filter cutouts and hinged vent hoods are provided as standard. Fans and filters are ordered separately.

Door: The front door is fabricated using 2.5mm marine grade aluminium and is designed to provide flush recessed mounting to prevent vandalism and unauthorised access. The door incorporates concealed removable hinges with captive pins. It is hinged on the left side, designed for a 110° opening and is provided with a heavy duty door stay. An A4 plan pocket is provided.

Seal: A high quality Polyurethane foamed in place (FIP) full perimeter door seals provide excellent sealing over a long life.

Lock: Single point locking system with key-lock swing handle. Optional locking including half euro keyed as required, restricted keys, Bilock and stainless steel padlockable.

Device Mounting Plate: The device mounting plate is 1.5mm galvanised steel sheet. It is pressed to provide strength and is pre-fitted into the enclosure as standard. Powder coated RAL9010 pure white.

Surface Treatment: UL approved AkzoNobel polyester powder coated with a smooth gloss finish, 80-120 micron average thickness, providing excellent exterior durability and colour retention. Colour RAL6005 Moss Green.

Mass: 10.3Kg.

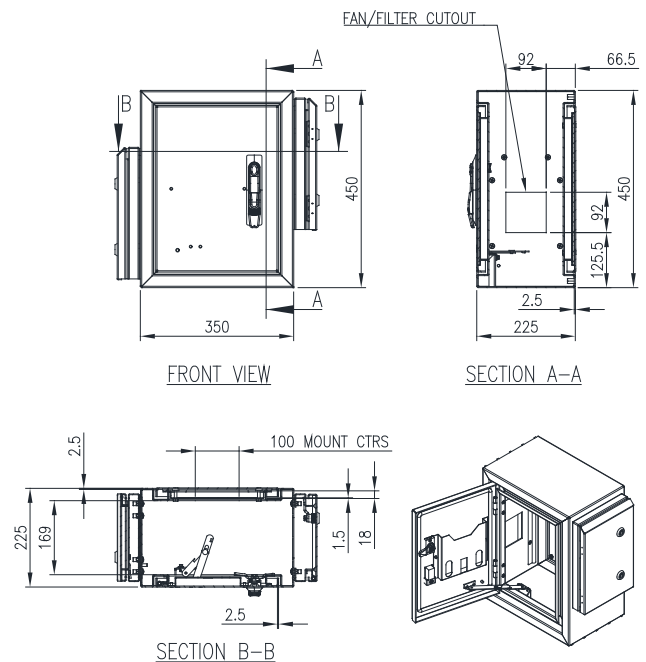

FCA Field Cabinet

IP-A453522-GRN

ALUMINIUM | POLE MOUNT | VENTILATED | IP55 IK10

450H x 350W x 225D

ACCESSORIES:

Part Number	Description
IP-A4535VENTDOOR-T33	Aluminium Enclosure Door with Ventilation; Powder-Coated
IP-APMB45	Aluminium Pole Mount Bracket to suit 450H x 350W x 225D Aluminium Field Cabinet
IP-FCABASE3522-T33	600H Aluminium Pedestal Base to suit 350W x 225D Field Cabinet T33 Smoke Blue

CERTIFICATES:

IEC 60529 Degrees of protection provided by enclosures: Certificate AB-0386-T 2009.33.02/00

IEC/EN 62208 Empty Enclosures for low-voltage switchgear and controlgear assemblies: Certificate 0366932-TSE-01/01

CE Certificate of Compliance: Certificate SZT-24 MA 33485-1

UKCA Certificate of Compliance: Certificate SZU-22 MA 19560-1

Products are manufactured to Quality, Safety and Environmental Standards.

WARRANTY: 5 years.