

S1 Electrical Enclosure

IP-604020

STEEL | SINGLE DOOR | IP66

600H x 400W x 200D

The S1 range of electrical enclosures are rated for protection up to IP66. This range is wall-mounted, powder-coated galvanised steel, single door construction suitable for heavy duty applications.

Protection: IP66 IK10 (NEMA 4)

Standards (& Conformities): IEC/EN 60529, IEC/EN 62208, IEC/EN 61439, RoHS



Material:

- Body: 1.2mm galvanised steel sheet
- Gland Plate: 1.5mm galvanised steel sheet
- Door: 1.5mm galvanised steel sheet
- Device Mounting Plate: 1.5mm galvanised steel sheet
- Seal: Polyurethane

Enclosure Body: The robust monoblock body is fabricated using 1.2mm galvanised steel sheet. Flat face sealing surfaces are provided to increase seal life. Pre-fitted blind nuts are incorporated to accommodate mounts and accessory fasteners to eliminate drilling and retain IP rating. Integral device plate mounts and M6 earth studs are provided. A galvanised steel gland plate is incorporated into the bottom face. Cutting, pressing and full continuous seam welding using precision automated manufacturing equipment ensures accuracy and consistent high quality.

Enclosure Door: The robust surface mounted door is fabricated using 1.5mm galvanised steel sheet and incorporates concealed removable hinges with captive pins. The door is designed for a 110° opening. Each door contains cable management rail, an M6 earth stud and a high quality machine-applied foamed in place (FIP) Polyurethane seal. Two internal cable management rails can be removed to provide additional space for equipment, duct and door mounted control components.

Enclosure Seal: A high quality machine-applied full perimeter UL listed Polyurethane seal foamed in place (FIP) provides excellent sealing over a long life. Temperature resistance -40°C to 80°C (160°C short term loading).

Enclosure Lock: 5mm double bit insert quarter turn lock and key.

Device Mounting Plate: The device mounting plate is 1.5mm galvanised steel sheet. It is pressed to provide strength and is pre-fitted into the enclosure as standard.

Gland Plate: Gland plates are incorporated into the bottom face of the enclosure for cable management. They are provided with gaskets and fasteners. The size and quantity vary according to enclosure size.

Surface Treatment: UL approved AkzoNobel epoxy polyester powder-coated with a textured finish. 80-120 micron average thickness. Colour RAL7035.

Mass: 13Kg.

Maximum Weight of Contents: 186Kg.

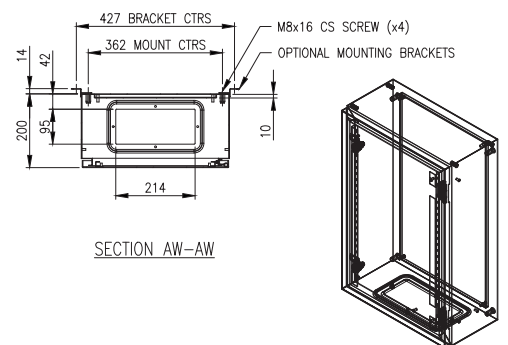
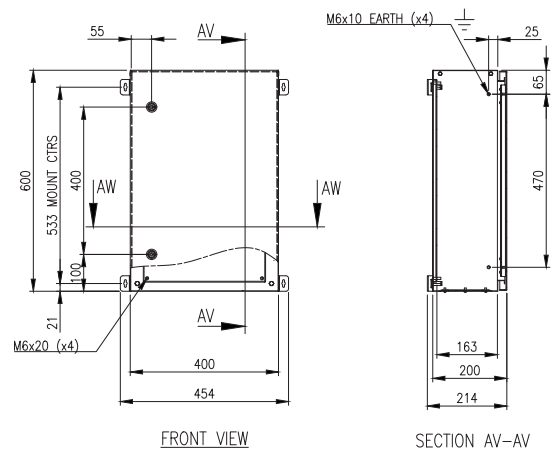

S1 Electrical Enclosure

IP-604020

STEEL | SINGLE DOOR | IP66

600H x 400W x 200D

ACCESSORIES:

Part Number	Description
IP-PSID6040	Steel Inner Door (To suit Enclosure 600mmH x 400mmW); Powder-Coated
IP-DB36	DIN Rail Kit - 36 Pole (To suit 600mmH x 400mmW x 200mmD Enclosure); Powder-Coated
IP-DINRAIL 7.5X35-330	DIN RAIL x 330mm (Pack of 10)
IP-GPB3-2; IP-GPA3-2; IP-GPBA5-2	3mm Brass; 3mm Aluminium; 5mm Aluminium Gland Plates
IP-EK01	Standard Earthing Kit
IP-PSRH4020	400mmW x 200mmD Steel Rain Hood; Powder-Coated
IP-SOL4020	Solar Panel Bracket Set (Including 2 Brackets and Fasteners)
IP-6040WINDOOR	600mmH x 400mmW IP66 Enclosure Door with Window; Powder-Coated
IP-6040VENTDOOR	Steel Enclosure Door with Ventilation; Powder-Coated
IP-WMBKIT	Wall-Mounting Bracket Kit (with 4x Brackets and Fasteners)
IP-PMP400	U-Channel Profile 400mm Long; Powder-Coated
IP-PMB	Pole Mount Bracket to Suit Large Diameter Poles (Use with Bandit Strap)
IP-L043	Wing Knob Padlockable; Cast Alloy Coated Black
IP-6040DOOR3PL	600H x 400W Door with 3-Point Locking and Key-Lock Swing Handle

CERTIFICATES:

IEC 60529 Degrees of protection provided by enclosures: Certificate AB-0386-T 1902.14 02/00
IEC/EN 62208 Empty Enclosures for low-voltage switchgear and controlgear assemblies: Certificate 0366932-TSE-01/01
IEC/EN61439-1, 61439-2 low voltage switchgear and controlgear assemblies: Certificate AB-0341-T, 23-297-R1-N1-1
CE Certificate of Compliance: Certificate SZL-21 MA 13338-1
UKCA Certificate of Compliance: Certificate SZU-22 MA 19560-1
UL: Listing Number E534557

IEC/EN 61439 Certified Test Ratings:

Rated Voltage:	400 V AC
Rated Insulation Voltage:	690 V
Rated Impulse Withstand Voltage:	6 kV
Rated Current:	630A
Rated Peak Withstand Voltage:	40kA
Rated Short-Time Withstand Current:	20kA (Busbar)
Rated Conditional Short Circuit Current:	20kA
Rated Frequency:	50Hz

Products are manufactured to Quality, Safety and Environmental Standards.

WARRANTY: 5 years.